



borgo®

Excellence in fixed seating and more

TEMPO





In 1984 Borgo was founded with the vision for reliable, forward-thinking furniture that is well designed and well built. We are a wholly Canadian owned company manufacturing in Toronto, Ontario.

Over the years, Borgo has become known for the quality of its products, and it's commitment to service, which is reflected in the number of repeat clients. The consistently well-manufactured product that we produce and our service record, have awarded us ISO 9001: 2008 registration.

Many of Borgo's Products have been tested and approved by both the Canadian and U.S. federal governments. Our "Supply Arrangement" and GSA business is a source of great pride.

Our future growth is based in the strength and experience of our past, but relies on our ability to see, anticipate and respond to the ever-changing requirements of an evolving working and learning environment.

We define excellence in fixed seating as enhancing the customer and user experience in every possible way. This begins with innovations in safety and comfort which lead to helping our customers create a space that strengthens the benefits for users.

Our expertise in fixed seating, in areas such as responsive customizing, Italian design and Canadian ingenuity, lends itself to our many offerings in corporate, hospitality and healthcare.

Eco-Friendly

As a company and community neighbour, we are exceedingly proud of the fact that Borgo manufactures products that are among the most sustainable in the industry. As a manufacturer of seating and case goods, each of us at Borgo understands our responsibility to continuously seek new technology, source progressive materials and develop better processes for producing our products and reducing our footprint on the earth. We are making the effort, and our footprint is getting smaller and smaller.

Some of the areas in which we have made notable progress are:

- Awarded August 4, 2009 following an audit by ameriGreen STRATEGIES Certification
- Borgo uses rapidly renewable materials and recycled content in more than 50% of our products.
- Overall, over 95% of the waste produced in our factories is now being recycled. The amount of waste being sent to the local landfill has been reduced by over 70%. And we are continuously working to improve these numbers.
- State of the art, largest textile cutting machine of its kind in North America has reduced our textile waste of up to 30%.

TRUE ANTI-PANIC TABLE

Fixed to the back, the fold-away table is made up of post-formed scratch-resistant bi-laminated wood composite with rounded front edges.

STANDING OUT

Tempo Evolution offers an acute leg. This design feature adds variety and the opportunity to customize any space.

PROTECTION AGAINST THE ELEMENTS

The back is equipped with a full wood, half wood or half metal option.

CURVED, STRAIGHT OR ANGLED

The Tempo offers a variety of arm options to truly make a theater or auditorium your own.



BUILT TO LAST

The Anti-Panic Tablet is bolted through and constructed of 5/16" (8mm) thick black high pressure laminate ensuring durability.

DESIGN FOR FLEXIBILITY

Rugged solid beech wood or elegant upholstered arm caps can make any space unique and beautiful.

INNER BEAUTY

This True Anti-Panic Tablet folds away effortlessly into the arm and out of the way.

DESIGN IN THE DETAILS

Outer and inner legs are kept consistent throughout for an aesthetically pleasing design.

CLEAN DESIGN

A crisp foot design hides any visible fasteners allowing for a clean look along the floor.

BEAUTY BUILT TO LAST

Structural steel frame with natural varnished beech wood legs for long lasting beauty.

TECHNOLOGICAL WORLD

Multi-media units can include power and microphones integrated right into the Tempo to meet the most technological demanding environments.



STYLE

9400 Standard
Center 21.25" (540 mm)

9410 Comfort
Center 22" (560 mm)

9900 Flared Standard
Center 21.25" (540 mm)

9910 Flared Comfort
Center 22" (560 mm)

9433 Evo Standard
Center 21.25" (540 mm)

9433 Evo Comfort
Center 22" (560 mm)

UPHOLSTERY

Tempo is available in standard Borgo fabrics, vinyls and leathers as well as COM.

ARM

 Fully upholstered
(standard)

 Solid beech wood arm
cap in natural stain

 Solid beech wood arm
cap in custom stain

 Solid beech wood arm
with upholstered arm
caps (Excludes Model
9900 and 9910)

SEAT

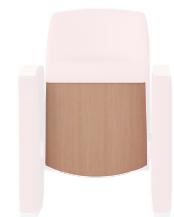
 Fully upholstered
(Standard)

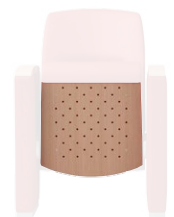
 Under seat in beech
plywood, natural stain

 Under seat in beech
plywood, custom stain

 Perforated under seat
in beech plywood, for
acoustical performance

BACK

 Lower back in black
powder coated steel
(Standard)

 Lower back protector
in natural stain beech
plywood

 Lower back protector
in custom stain beech
plywood

 Full back in beech
plywood in natural
finish

 Full back in beech
plywood in custom
stain

KICKPLATE

- Black Powder Coated Steel (Standard)

- Solid Beech Wood (Matching Wood Arm)

OPTIONS

- Concealable Anti-Panic Tablet (Folds into Arm)
- Anti-Panic Table (Attached to back of seat in front)
- Seat number
- Aisle number
- End Row Light: Incandescent or L.E.D.
- Power
- Cup holder

TABLE

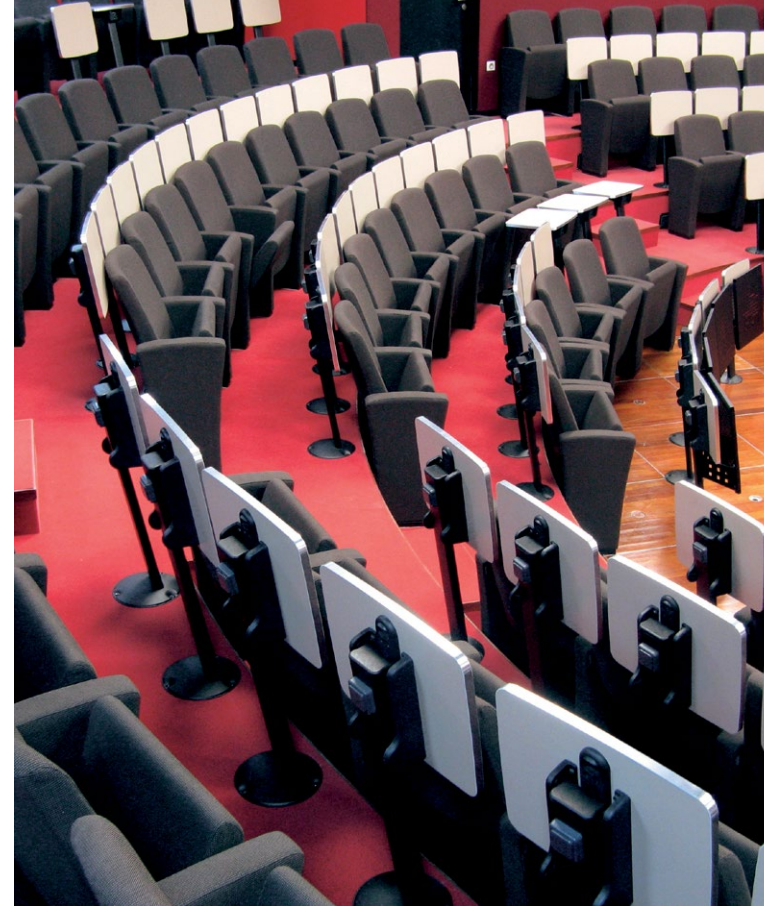
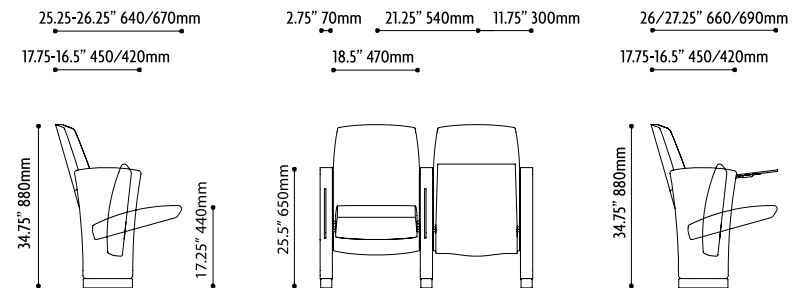
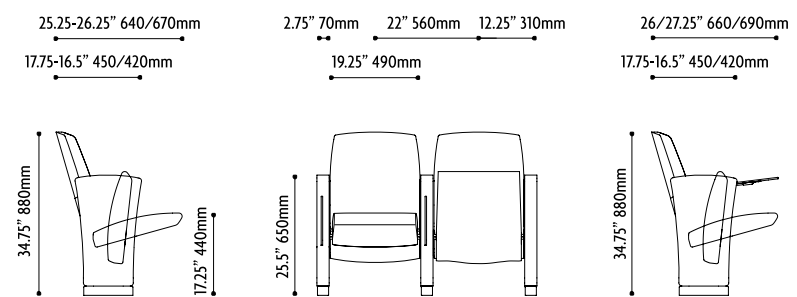
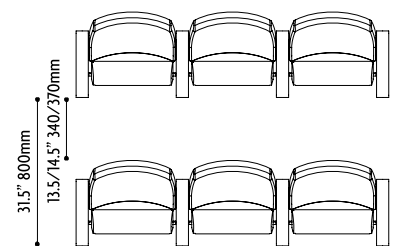
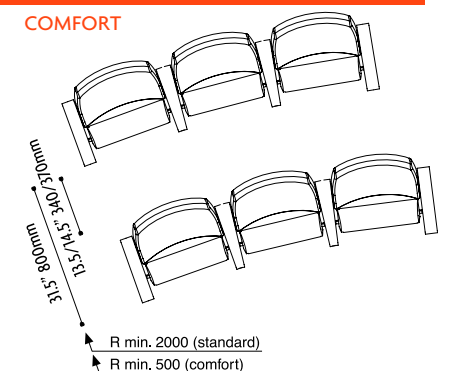
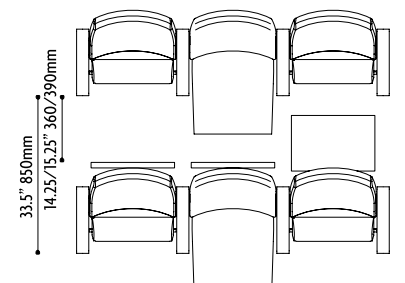
 Stand alone tip-up writing
surface in natural beech post-
formed laminate top, and gray
powder coated steel base.

DIMENSIONS

STANDARD

COMFORT

WRITING TOP ON THE BACK

* All models comes standard with all metal components in black



borgo.com

